

راهنمای جراحی ایمپلنت DPI

GUIDE SURGURY OF DPI IMPLANT SYSTEM

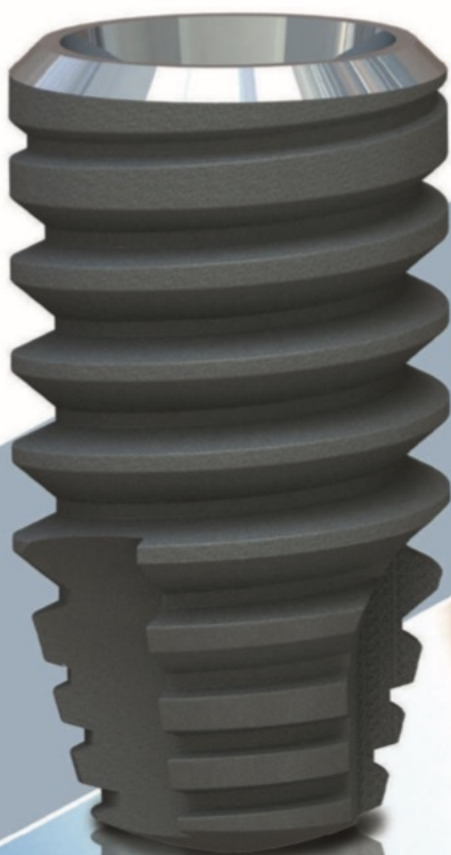

*...Creating smiles
with a gentle touch...*



PARS SAMAN TEB
Exclusive Sales
Representative

FEATUERS & BENEFIT

DRILLING PROTOCOL FOR DPI IMPLANT

CAVITY PREPARATION :

Every person has a unique bone structure and the clinician has to adapt the drilling protocol to the individual bone quality and anatomical situation. Our drilling protocol is an optimal scheme for different types of bones: D1, D2- D3, D4.

DRILLING SPEED:

Recommended drilling speed:

- initial drilling – 1200–1500 Rpm;
- pilot drilling – 900–1200 Rpm;
- form drilling – 200–800 Rpm.

Implantologist is responsible of drilling speed choice, taking into consideration his experience, preferences and special necessities of the patient.

Important notice: this protocol was prepared with a max speed of 700 rpm ,with insertion torque for implants is from 35 to 50 Ncm.

IMPLANT POSITION:

1. Crestal implant position.
2. Implant can be placed 1-2 mm deeper to help bone grow over implant - subcrestal implant position

For the 2 option drilling should go 1-2 mm deeper than implant length.



DPI implants installation using tapered drills

DRILLS:

Lindemann drill can be used for initial drilling by setting the drilling axis before using pilot drill .

Drill with tapered drills to the appropriate depth, required for a specific case.

If after using the previous drill the torque is still more than 50 Ncm while inserting the implant, the cavity has to be widened.

Point Lindemann Drill



Initial Drill

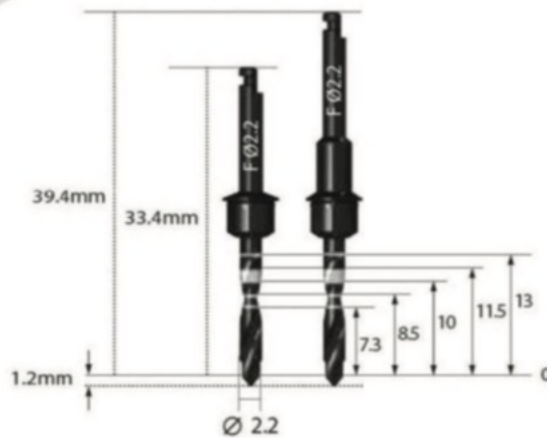

Tapered drills have V-shaped tips, for better correlation with the implant, 3 cutting edges offer good stability. The tapered shape reduces frictional heating. Variable helix for enhanced drilling control and twisted flute for bone extraction.

Angled back cutting edge allows compressing of bone when drilling in counter-clock wise (reverse).

• Cortical Drill

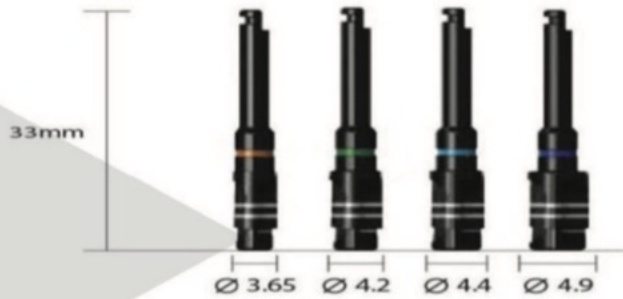

Diameter	Product name
Ø3.65	CD35F
Ø4.2	CD40F
Ø4.4	CD45F
Ø4.9	CD50F

• Stopper

Stopper	3.0	4.0	5.0	6.0	6.6	7.0	8.5	10.0	11.5	13
Drilling Length(mm)	4.2	5.2	6.2	7.2	7.8	8.5	9.7	11.2	12.7	14.2
Product name	DS030C	DS040C	DS050C	DS060C	DS066C	DS070C	DS085C	DS100C	DS115C	DS130C

※ Stoppers cannot be connected to Ø4.9 Twist Drill(TSD49F) only

NOTE:

For the best result it is recommended to use a smaller diameter drill and try inserting the implant.

Warning: Due to the function and design of the drills, the drill tip is up to 1.0 mm longer than the insertion depth of the implant. For example, if you drill until the 10 mm marking the actual osteotomy has a depth of 11 mm.

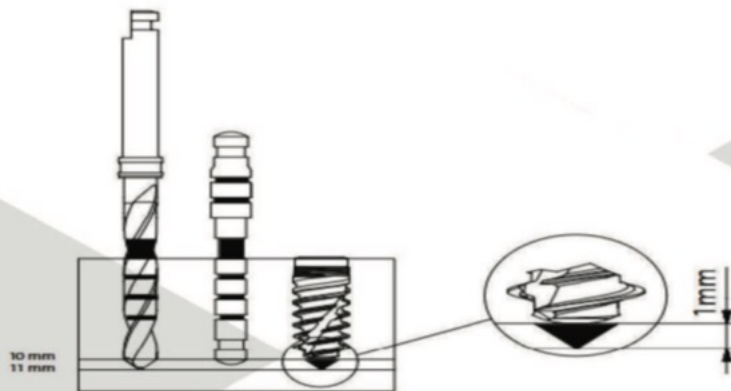

Drill extender:

The stop ring reduced the effectiveness of the irrigation when a drill extender is used. In this case use additional external irrigation (e.g with a syringe) to ensure proper cooling of the osteotomy during drilling.



Alignment pins:

Two lengths of alignment pins are available for accurate depth measurements and alignment of orientation and position of the osteotomy.

Implant depth gauge:

Implant depth gauge for accurate depth measurement and tactile examination of the osteotomy.

> Ø 2.1 mm end: use to examine osteotomy made by drill No. 1 (Ø 2.2 mm) and by No. 2 (Ø 2.8 mm)

> Ø 2.9 mm end: use to examine osteotomy made with drill No. 3 (Ø 3.2 mm) and wider.

Made of titanium-alloy (TAN).

Implant driver:

Specific Implant Driver to use for pick-up and insertion of the DPI Implants.

- Fixture Driver

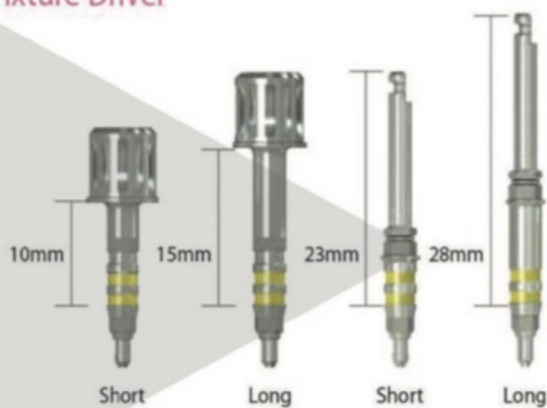

Length	Product name
Ratchet (Short)	FD10R
Ratchet (Long)	FD15R
Contra Angle (Short)	FD05C
Contra Angle (Long)	FD05CL

Note: The Implant Driver for handpiece, long is compatible with a manual surgical implant drivers.

If manual surgical implant drivers are used to insert the implant, special attention is required to avoid overtightening.

Ratchet and torque control devices:

The ratchet is a two-part lever arm instrument with a rotary knob for changing the direction of force. It is supplied with a service instrument, which is used to tighten and loosen the head screw.

- Torque Ratchet



Note: To ensure prolonged perfect function, the ratchet must always be taken apart and the individual parts disinfected, cleaned and sterilized after use. Its function must be checked in good time before each use.

Surgical cassette:

The DPI Surgical Cassette is used for the secure storage, cleaning and sterilization of the surgical instruments and auxiliary instruments. For guidelines on how to clean and sterilize the cassette with or without inserted instruments, please see catalog product.



Surgical procedure:

The workflow for the surgical procedure for the DPI implant System involves 3 steps:

Preoperative planning

Implant bed preparation

Implant insertion

Preoperative planning:

Prosthetic-driven planning is recommended, and close communication between the patient,

dentist, surgeon and dental technician is imperative for achieving the desired esthetic result.

To determine the topographical situation, axial orientation and the appropriate implants, making a wax-up / set up using the previously prepared study cast is recommended. Subsequently, the type of superstructure can be defined. The wax-up / set-up can later be used as the basis for a custom-made x-ray or drill template and for a temporary restoration.

The following three rules should be regarded as minimum guidelines:

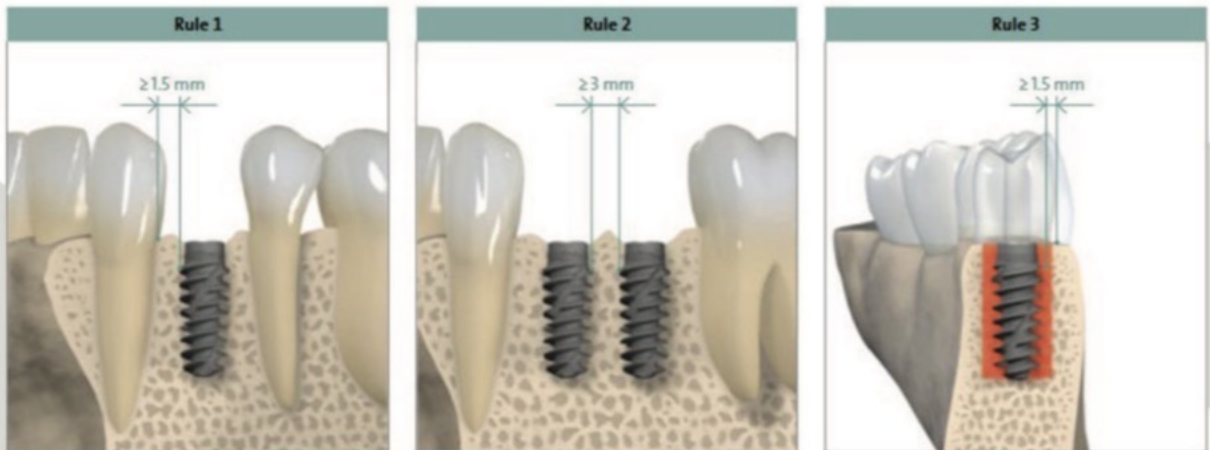

Rule 1: Distance to adjacent tooth at bone level A minimum distance of 1.5 mm from the implant adjacent tooth (mesial and distal) is recommended.

Rule 2: Distance to adjacent implants at bone level A minimum distance of 3 mm between two adjacent implant shoulders (mesiodistal) is recommended.



Rule 3: The facial and palatal bone layer must be at least 1.5 mm thick in order to ensure stable hard and soft tissue conditions.

Within this limitation, a restoration-driven orofacial implant position and axis should be chosen such that screw-retained restorations are possible.

Note: Abutments should always be loaded axially. Ideally, the long axis of the implant is aligned with the cusps of the opposing tooth. Extreme cusp formation should be avoided as this can lead to unphysiological loading.

the inter-implant distances if multiple implants are placed. The point of reference on the implant for measuring mesiodistal distances is always the largest diameter of the implant.

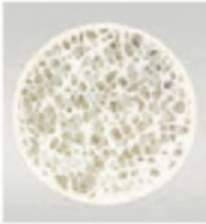
Caution: An augmentation procedure is indicated if the orofacial bone wall is less than 1.5 mm or a layer of bone is missing on one or more sides. This technique should be employed only by dentists with adequate experience in the use of augmentation procedures.

Cross sectional view of different types of bone quality*		
Type I	Type II/III	Type IV
Hard	Medium	Soft
Thick cortical bone with marrow cavity	Thin cortical bone with dense trabecular bone of good strength	Very thin cortical bone with low density trabecular bone of poor strength
		

Implant bed preparation:

The DPI Surgical Cassette with specific instruments is used to prepare the implant bed. Different drill protocols should be employed depending on the bone density. This offers the flexibility to adapt the implant bed preparation to the individual bone quality and anatomical situation.

A quick guide to the surgical drill protocol is printed on the DPI surgical cassette and indicates the final drill recommended for each implant diameter and bone density.

Note: Every implant bed has to be initiated with the pilot drill (\emptyset 2.2 mm). On the quick guide only the final drill is displayed. The clinician can decide whether or not a sequence of drills with increasing diameters is used. Use the drills in a clockwise drill rotation direction, use intermittent drilling technique and provide ample cooling with pre-cooled (5°C, 41°F) sterile saline solution. Do not exceed the recommend drill speeds.

Implant Drilling Protocol by Bone Type

Implant Ø	Bone Type	Pilot Drill	Intermediate Drill 1	Intermediate Drill 2	Final Drill	Tap / Countersink	Modifications / Notes
3.7 mm	D1	Ø 2.0 mm	Ø 2.8 mm	Ø 3.2 mm	Ø ~3.6 mm	Tap: YES / Countersink : YES	Use all stages; reduce torque; slow rpm final drills
3.7 mm	D2	Ø 2.0 mm	Ø 2.8 mm	Ø 3.2 mm	Ø ~3.7 mm	Tap: optional / Countersink : YES	Possibly skip intermediate drill 2 if dense
3.7 mm	D3	Ø 2.0 mm	Ø 2.8 mm	—	Ø ~3.4-3.5 mm	Tap: NO / Countersink : optional	Undersize final; skip some intermediates
3.7 mm	D4	Ø 2.0 mm	—	—	Ø ~3.2-3.4 mm	Tap: NO / Countersink : NO	Significant undersize; minimal drilling
4.0 mm	D1	Ø 2.0 mm	Ø 2.8 mm	Ø 3.2 mm	Ø ~3.8-4.0 mm	Tap: YES / Countersink : YES	Use full drill sequence; possibly countersink
4.0 mm	D2	Ø 2.0 mm	Ø 2.8 mm	Ø 3.2 mm	Ø ~4.0 mm	Tap: optional / Countersink : YES	Might skip intermediate 3 in very hard cortical zone
4.0 mm	D3	Ø 2.0 mm	Ø 2.8 mm	—	Ø ~3.6-3.8 mm	Tap: NO / Countersink : optional	Undersize final to improve primary stability
4.0 mm	D4	Ø 2.0 mm	—	—	Ø ~3.4-3.6 mm	Tap: NO / Countersink : NO	Minimal drilling; major undersize
4.5 mm	D1	Ø 2.0 mm	Ø 2.8 mm	Ø 3.6 mm	Ø ~4.4-4.5 mm	Tap: YES / Countersink : YES	Use all stages; torque control; possible cortical widen
4.5 mm	D2	Ø 2.0 mm	Ø 2.8 mm	Ø 3.6 mm	Ø ~4.5 mm	Tap: optional / Countersink : YES	Could skip one intermediate if cortical is less dense
4.5 mm	D3	Ø 2.0 mm	Ø 2.8 mm	—	Ø ~4.0-4.3 mm	Tap: NO / Countersink : optional	Undersize final; skip intermediates as needed

4.5 mm	D4	Ø 2.0 mm	—	—	Ø ~3.8-4.1 mm	Tap: NO / Countersink : NO	Maximal undersize; minimal drilling
5.0 mm	D1	Ø 2.0 mm	Ø 2.8 mm	Ø 3.6 mm	Ø ~4.8-5.0 mm	Tap: YES / Countersink : YES	Use all drills; possible coronal widening in crest zone
5.0 mm	D2	Ø 2.0 mm	Ø 2.8 mm	Ø 3.6 mm	Ø ~5.0 mm	Tap: optional / Countersink : YES	Skip a stage if bone is less thick cortical layer
5.0 mm	D3	Ø 2.0 mm	Ø 2.8 mm	—	Ø ~4.2-4.6 mm	Tap: NO / Countersink : optional	Undersize final; reduce intermediate drills
5.0 mm	D4	Ø 2.0 mm	—	—	Ø ~4.0-4.4 mm	Tap: NO / Countersink : NO	Strong undersize; minimal drilling



OPI

DENTAL IMPLANTS SYSTEM

www.Parssamanteb.com

 @Parssamantebco

Head office :
Pars Saman Teb Co.
No. 22, East 35th St. , South Sarrafha St.,
Saadat Abad, Tehran, Iran
Tel: +98 2122749458

